

# TAFCO

*Walk-In to Quality*

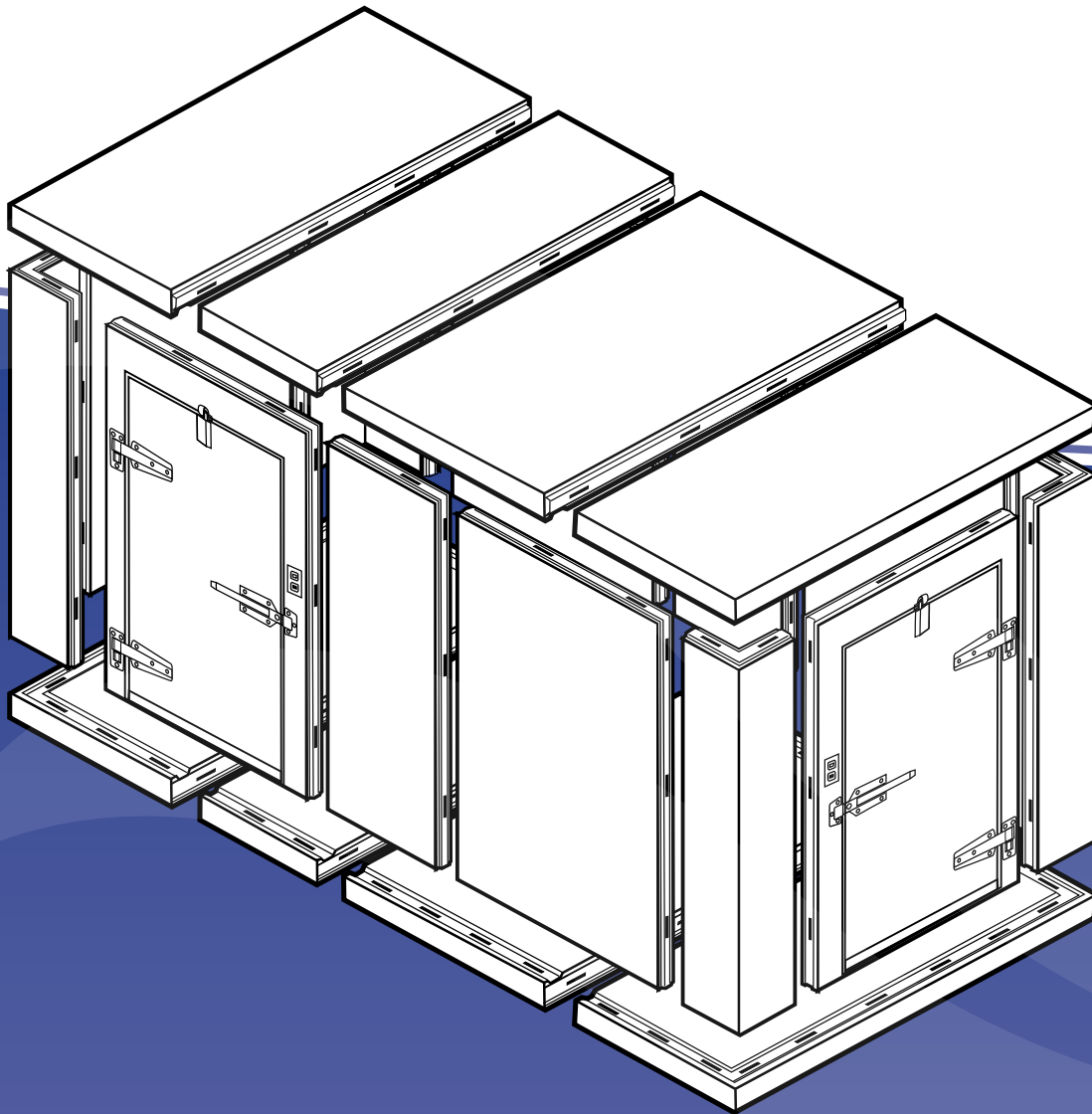

Energy Independence and Security Act of 2007 Compliant



## PRODUCT GUIDE

# PANEL FABRICATION

Better panel fabrication means one thing: better walk-ins. The panels consist of urethane insulation, which is sandwiched between interior and exterior metal “skin”. This metal skin has been die-formed and gauged for uniformity in size. The edges of the panels are tongue and groove with Tafco SureLock fasteners which are “foamed-in-place” at time of fabrication.

The panels are provided with NSF listed PVC gaskets which are “foamed-in-place” on both interior and exterior sides of the panel. The gaskets are impervious to all stains, greases, oils, mildews, etc. They ensure an air-tight seal and also eliminate the need for seam caulking.

The urethane foam is bonded to the inner surfaces of metal pans, having an average thermal conductivity (K factor) of 0.13 BTU/hr/ft<sup>2</sup>/degrees/Fahrenheit/inch. Also, the panels have an overall coefficient of heat transfer (U factor) of no more than 0.0312. As tested in accordance with ASTM C 518-2004, the R-factor for coolers at temperatures of 55 °F is greater than 29.0 for 4” thick panels. The R-factor for 5” thick panels is greater than 36.0. For freezers at temperatures of 20 °F, the R factor is greater than 32.0 for 4” thick and greater than 40.0 for 5” thick panels.

The prefabricated urethane foamed panels shall be supplied with a Class 1 fire hazard classification according to UL 723 (ASTM-E-84), as tested by Underwriters Laboratories, Inc. Panels shall have a flame spread rating of 25 or less and bear a certified Underwriters Laboratories, Inc. label.



Tafco prides itself in using CFC free foam. This environmentally friendly foam is 100% CFC and HCFC Free, with a 0% ODP (ozone depletion potential).

Panels are offered with a wide variety of metal and other finishes. These include Galvalume, Stainless Steel, Aluminum, Galvanized Steel, Embossed, Smooth, White, San Tan, FRP, antimicrobial coated metal, and multiple color finishes.



Mean Temperature for Freezer 20°	
K-Factor = .1232	R-Factor = 8.12 per inch
R-Factor 4” Panel = 32.5	U-Factor 4” = .031
R-Factor 5” Panel = 40.6	U-Factor 5” = .025
R-Factor 6” Panel = 48.7	U-Factor 6” = .021

Mean Temperature for Cooler 55°	
K-Factor = .1375	R-Factor = 7.26 per inch
R-Factor 4” Panel = 29.04	U-Factor 4” = .035
R-Factor 5” Panel = 36.3	U-Factor 5” = .027
R-Factor 6” Panel = 43.6	U-Factor 6” = .023



# MODULAR FLEXIBILITY

Tafco cooler and freezer panels are available in hundreds of sizes, allowing flexibility of design. We are able to make almost any size and shape box, ensuring we can meet your specific space requirements. Panels come in many standard sizes, with custom size panels available upon request. These light-weight modular panels are easy to handle and allow assembly, disassembly, relocation, and expansion. On average, two men can assemble an 8' x 10' walk-in in approximately three hours. The ease of changing out panels ensures that if future expansion of your walk-in is ever necessary, reconfiguration is easy.

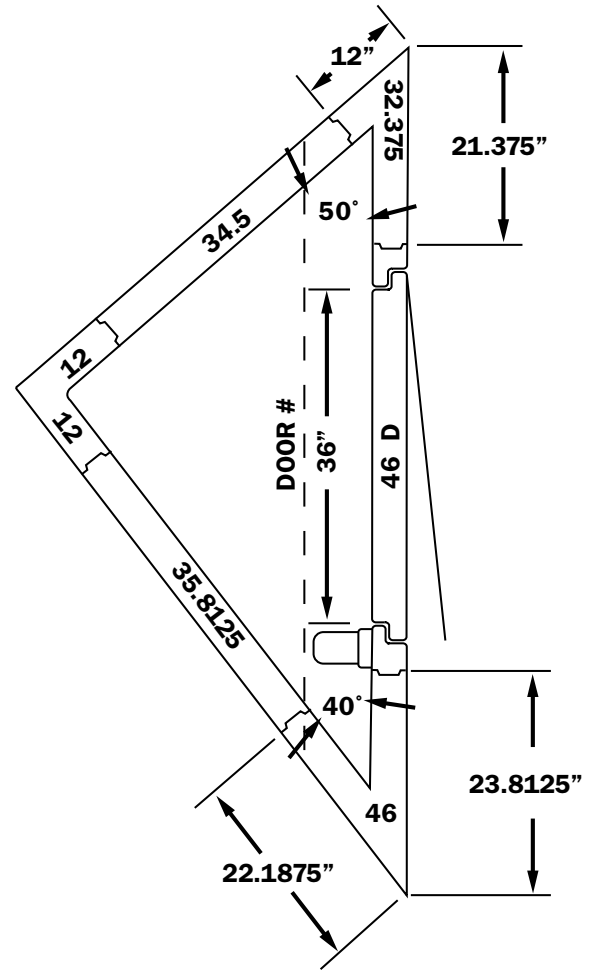

**Reference Table for Total Overall Nominal and Actual Dimensions**

Nom	Actual	Nom	Actual	Nom	Actual	Nom	Actual	Nom	Actual	Nom	Actual
4'	3'11"	21'	20' 2.5"	37'	36' 6"	53'	52' 9.5"	70'	69' 1"	86'	85' 4.5"
5'	4' 10"	22'	21' 2"	38'	37' 5.5"	54'	53' 9"	71'	69' 0.5"	87'	86' 4"
6'	5' 10"	23'	22' 1.5"	39'	38' 5"	55'	54' 8.5"	71'	71' 0"	88'	87' 3.5"
7'	6' 9.5"	24'	23' 1"	40'	39' 4.5"	56'	55' 8"	72'	71' 11.5"	89'	88' 3"
8'	7' 9"	25'	24' 0.5"	41'	40' 4"	57'	56' 7.5"	73'	72' 11"	90'	89' 2.5"
9'	8' 8.5"	25'	25'	42'	41' 3.5"	58'	57' 7"	74'	73' 10.5"	91'	90' 2"
10'	9' 8"	26'	25' 11.5"	43'	42' 3"	59'	58' 6.5"	75'	74' 10"	92'	91' 1.5"
11'	10' 7.5"	27'	26' 11"	44'	43' 2.5"	60'	59' 6"	76'	75' 9.5"	93'	92' 1"
12'	11' 7"	28'	27' 10.5"	45'	44' 2"	61'	60' 5.5"	77'	76' 9"	94'	93' 0.5"
13'	12' 6.5"	29'	28' 10"	46'	45' 1.5"	62'	61' 5"	78'	77' 8.5"	94'	94' 0"
14'	13' 6"	30'	29' 9.5"	47'	46' 1"	63'	62' 4.5"	79'	78' 8"	95'	94' 11.5"
15'	14' 5.5"	31'	30' 9"	48'	47' 0.5"	64'	63' 4"	80'	79' 7.5"	96'	95' 11"
16'	15' 5"	32'	31' 8.5"	48'	48' 0"	65'	64' 3.5"	81'	80' 7"	97'	96' 10.5"
17'	16' 4.5"	33'	32' 8"	49'	48' 11.5"	66'	65' 3"	82'	81' 6.5"	98'	97' 10"
18'	17' 4"	34'	33' 7.5"	50'	49' 11"	67'	66' 2.5"	83'	82' 6"	99'	98' 9.5"
19'	18' 3.5"	35'	34' 7"	51'	50' 10.5"	68'	67' 2"	84'	83' 5.5"	100'	99' 9"
20'	19' 3"	36'	35' 6.5"	52'	51' 10"	69'	68' 1.5"	85'	84' 5"	101'	100' 8.5"

# STANDARD WALL & PANEL SIZES

 5' - 10"

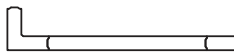
 6' - 9.5"

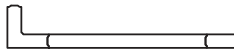
 7' - 9"

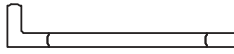
 8' - 8.5"

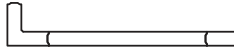
 9' - 8"

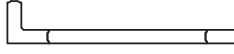
 10' - 7.5"

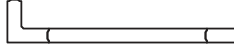
 11' - 7"

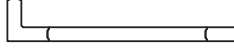
 12' - 6.5"

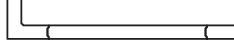
 13' - 6"

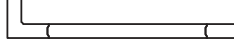
 14' - 5.5"

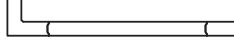
 15' - 5"

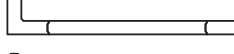
 16' - 4.5"

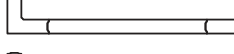
 17' - 4"

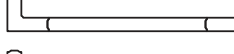
 18' - 3.5"

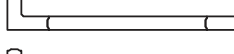
 19' - 3"

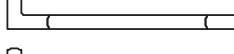
 20' - 2.5"

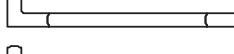
 21' - 2"

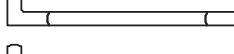
 22' - 1.5"

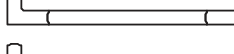
 23' - 1"

 24' - 0.5"

 25' - 0"

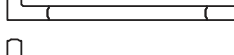
 25' - 11.5"

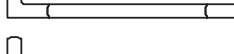
 26' - 11"

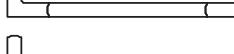
 27' - 10.5"

 28' - 10"

 29' - 9.5"

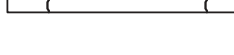
 30' - 9"

## Standard Walk-In Heights, Floorless

6' 2.5"; 7' 2.5"; 8' 2.5"; 9' 2.5"; 10' 1.5"

## Standard Walk-In Heights, with Floors

6' 6.5"; 7' 6.5"; 8' 6.5"; 9' 6.5"; 10' 5.5"

## Maximum Panel Height

288" (24')

## Door Frames

46" with 30", 34", or 36" door

57.5" with 30", 34", 36", or 42" door

69" with 48" door

80.5" with 60" door

## Floor & Ceiling Mid Sections

11.5", 23", 34.5", 46"

## Floor & Ceiling End Sections

35"

## Corners

12" x 12"

# STANDARD BOX SIZES

Tafco boxes come in many standard sizes. Use the chart at the right to layout the correct size walk-in for your application. You may also request special size boxes in addition to our standards. Our Engineering team will be glad to assist you in designing the correctly sized box for your specific needs.

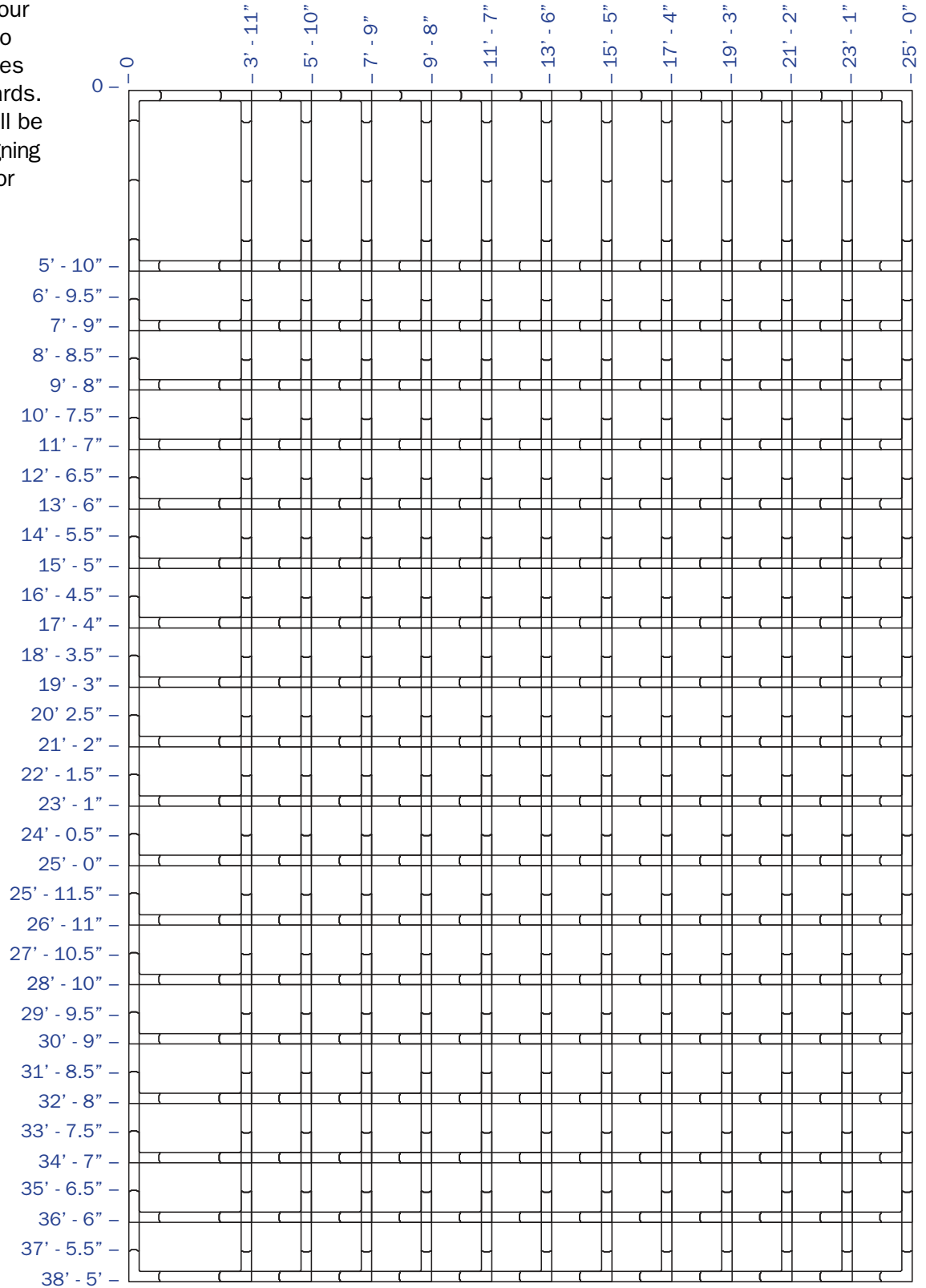

# WALK-IN FINISHES

Tafco offers a variety of metal finishes to make your walk-in look exactly as you imagined. Below are samples of available finishes, which also include antimicrobial coated metals and FRP. For other options, please consult the factory.



**.032 White  
Embossed Aluminum**

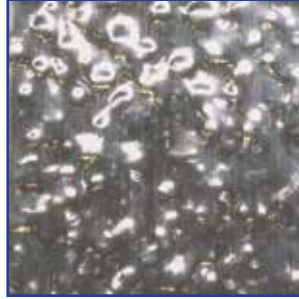

**20 Gauge Embossed  
Stainless Steel**

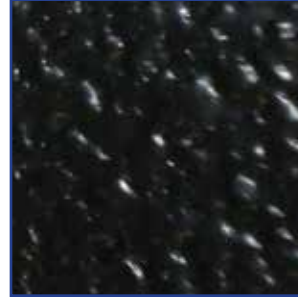

**26 Gauge Black  
Embossed Galvalume**

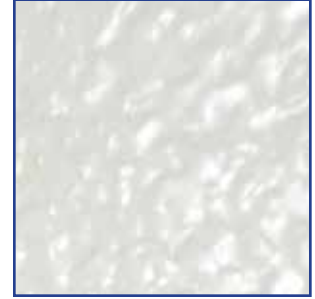

**26 Gauge White  
Embossed Galvanized  
Steel**



**24 Gauge Sierra Tan  
Galvalume**

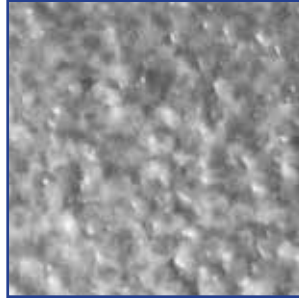

**26 Gauge  
Embossed Galvalume**



**.040 White  
Smooth Aluminum**

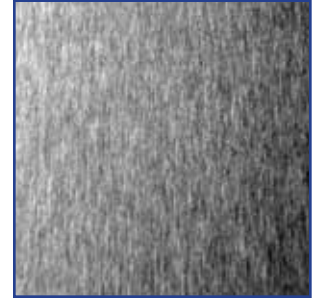

**22 Gauge Smooth  
Stainless Steel**

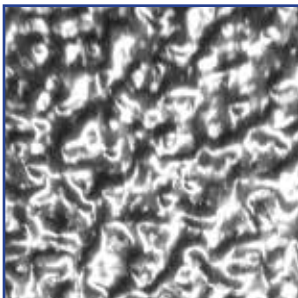

**.032 Embossed  
Aluminum**

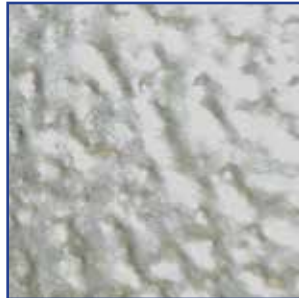

**26 Gauge Embossed  
Galvanized Steel**



**5-bar**

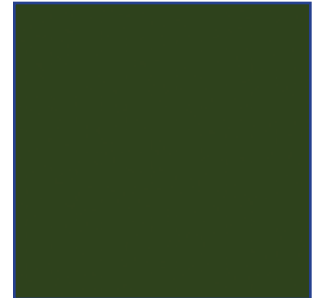

**Painted Finish  
Any Color**

\*actual colors may vary

# GALVALUME

Tafco is proud to announce that we have transitioned to a superior coating in Q4, 2010 and Q1, 2011. Acrylic coated galvalume is an aluminum-zinc steel that provides extra corrosion protection when compared to galvanized steel.

Acrylic coated galvalume offers the best qualities of aluminum-coated (aluminized) and zinc-coated (galvanized) steels. It has barrier corrosion resistance and heat resistance similar to aluminized. It also has good bare edge galvanic protection and forming qualities like galvanized. Acrylic coated galvalume will resist rust, the elements, and fire while providing a sturdy and protective covering.

## Some of the advantages of acrylic coated galvalume, when compared to galvanized or aluminized steel, include:

- Resists finger, hand, and foot printing during installation
- Provides a bright appearance which will weather uniformly
- Has excellent resistance to darkening or staining
- Clear protective coating
- The metal skins come with a 20 year rust-through warranty

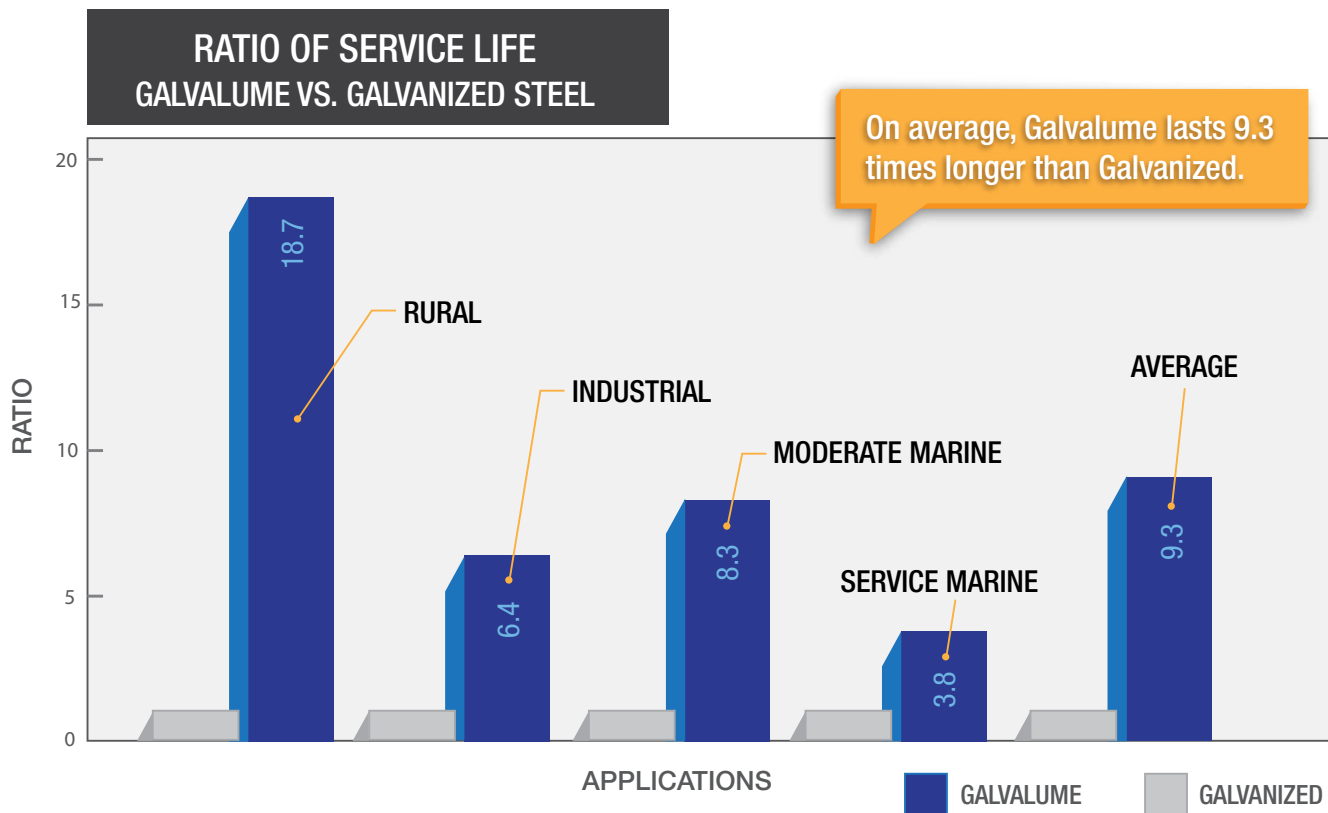

## An added advantage of galvalume verses galvanized or aluminized steel:

Galvalume's thermal reflectivity results in a 50% reduction in the heat from solar radiation penetrating the box, thus reducing thermal loads. In addition to reflecting heat away from the box, galvalume coating more efficiently retains the cold within the box when compared to galvanized steel.

# ANTIMICROBIAL

## How Antimicrobial Coating Works:

Tafco's antimicrobial coating, applied to the exterior of our refrigeration products, inhibits the growth of bacteria, molds, fungi, and other microbes, through the controlled release of silver ions. This provides continuous antimicrobial protection for the product for the life of the coating.

## Coating Life and Application:

The antimicrobial coating is applied as a clear paint system or a tinted system. Coating life is a function of the application and surface wear, but generally averages 10-30 years, depending on the wear the product experiences.

Note: Although silver ion is a powerful antimicrobial agent, the Tafco antimicrobial coating is not intended as a substitute for good cleanliness. Coated refrigeration products must still be cleaned to ensure that surfaces will be free of destructive microbes.

## Insulated Structure Applications:

Tafco's antimicrobial-coated steel adds value to your Insulated Structures. There is growing public awareness of destructive microbes. Many industries have attempted to address customer concerns regarding microbes. Tafco now provides this important value-added solution to the refrigeration system that you've invested in. Particularly, for those companies in the food services industry, the revolutionary antimicrobial protective coating is a must for food appliances and products, including your refrigeration system.

## Refrigeration:

While temperatures below 40° F typically inhibit the growth of many microbes, even at colder temperatures, Tafco's antimicrobial coated steel works to inhibit these growths. In short, no matter what the environment, this coating makes a big difference with no process or operating changes.

**The world around us is full of microbes. While many are harmless, some can cause serious illness and disease. Molds and mildews can also cause costly damage to vital equipment. As a leader in high quality refrigeration systems and walk-ins, Tafco remains committed to progressive innovations in its products, as demonstrated by employing protective antimicrobial coatings.**

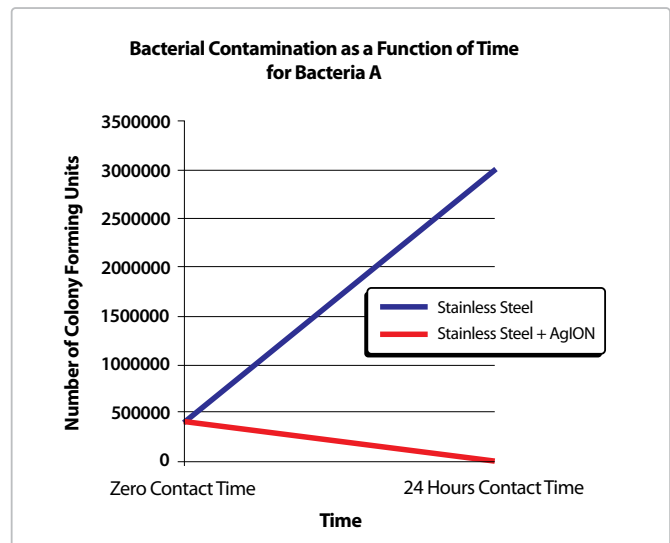
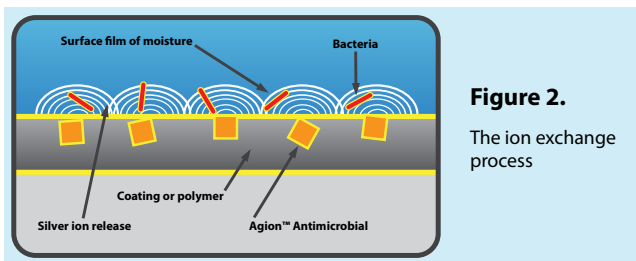
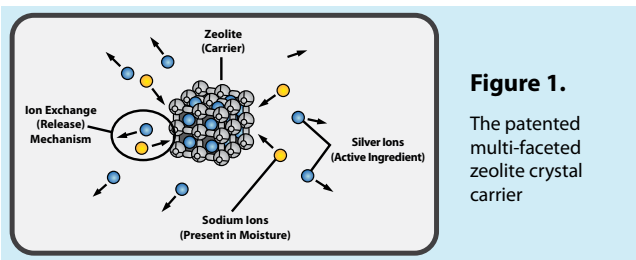



# QUALITY PRODUCTS & HIGH STANDARDS

## Quality Policy

“Our policy is to provide our customers with a quality product that fully satisfies their requirements. On-time delivery and conformance to requirements are constant objectives. We strive to continually improve the quality management system and all processes of the system. Employees are encouraged to initiate improvements and to participate in improvement activities. We are committed to fulfilling our commitment to our employees and community by maintaining a safe working environment and by meeting all statutory and regulatory requirements.”



## EISA Compliant

We take pride in providing our customers with products that are compliant with the Energy Independence and Security Act of 2007. This act was signed into law on December 19, 2007 and became effective January 1, 2009. Since this date we have shipped out only walk-ins that comply.



## Factory Mutual FM

Tafco panels are available with FM 4880 approval. FM Approved insulated panels have a flame spread of 25 and a smoke density of 400, subject to conditions described in FMRC Standard 4880.



## U.S. Green Building Council (USGBC)

USGBC has a mission to transform the way buildings and communities are designed, built, and operated, enabling an environmentally and socially responsible, healthy, and prosperous environment that improves the quality of life. Tafco is participating with the USGBC to help our customers attain LEED certification. LEED is an internationally recognized green building certification system, providing third-party verification that a building or community was designed and built using strategies aimed at improving performance across all the metrics that matter most: energy savings, water efficiency, CO2 emissions reduction, improved indoor environmental quality, and stewardship of resources and sensitivity to their impacts.



## NSF Certification

Tafco (TMP Manufacturing Company, Inc.) foodservice products are certified by NSF to NSF/ANSI Standard 7.



## U.S. Small Business Administration Hub Zone Certified

As of May 01, 2009, Tafco is a HUB Zone certified business approved under the North American Industry Classification System (NAICS) Code. The HUB Zone Empowerment Contracting Program stimulates economic development and creates jobs in urban and rural communities by providing Federal contracting preferences to small businesses. These preferences go to small businesses that obtain HUB Zone (Historically Underutilized Business Zone) certification, in part, by employing staff who live in a HUB Zone.



## Underwriters Laboratories UL

Building Units are UL Classified control number R8380 and have a flame spread of 25 and smoke development of 300. Door Panels are UL Listed control number E44455.

Tafco walk-ins are acceptable for use in accordance with the Report of Materials and Equipment Acceptance (MEA) Division of the City of New York Department of Buildings, approval number MEA 297-96-M.



## ISO 9001:2008 Certification

TAFCO (TMP Manufacturing Company Inc.) has achieved ISO 9001:2008 certification, the latest ISO standard designation. Tafco received its certificate from Bureau Veritas Group. This demonstrates Tafco's commitment to quality-of-service standards established by the International Organization for Standardization (ISO).

***Our products are made with pride in the USA.*** 

# WALK-IN DOOR & BOX ACCESSORIES

Tafco doors are among the best in the industry. Our doors are available in standard opening sizes of 30", 34", and 36", along with custom sizes as well. Tafco doors come with an assortment of accessories and options to meet your specific requirements. We also offer Manual and Electric, horizontal single, bi-parting sliding and vertical doors. Most accessories are also available with an antimicrobial coating.

## 1. Hinges

Standard hinges are self-lubricating, reversible, and very durable. They offer reinforcing ribs for extraordinary strength and are aesthetically pleasing. We offer many other hinge types as well.

## 2. Door Closer

Our standard door closer permits fast door closure to make sure the cold stays inside. Standard door closer is solid stainless steel throughout and is built for years of trouble-free use.

## 3. Pressure Relief Port (PRP)

A PRP is part of standard installation on all coolers and freezers to equalize pressure between the interior and exterior, caused by sudden pressure changes. The port allows doors to open and close with ease and reduces stress on walk-in joints.

## 4. Pull Handles & Latches

A standard heavy-duty, ergonomically designed pull handle allows comfortable, easy door opening. It features concealed, tamper-resistant mounting and is NSF listed. Pull handles are combined with a separately mounted locking hasp that provides optimum security and a glow-in-the-dark quick release, inside safety mechanism. We also feature locking pull handles and positive latch options.

## 5. Thermometer / Alarms / Motion Sensors / Switches

Standard thermometers and light switches feature LED displays with 1 second, 1 minute, or 3 minute display updates. They also feature an illuminated light switch, allowing operators to turn on the walk-in light easily. We also offer many different types of dial thermometers and switches including motion sensor, interval timer, alarm, light manager, fan control, and piloted flip.

## 6. Viewports

To allow easy visibility of your product through a Tafco door, we offer standard sized 14" x 14", 14" x 24", and custom size heated or unheated viewport windows. These viewports have tempered, triple-pane, moisture proof, clear glass viewing areas. They have fully welded PVC framing, which provides positive insulation barriers, eliminating heat transfer and sweating. Viewports are filled with Argon to comply with the Energy Independence and Security Act of 2007.

## 7. Tuffy Doors and Kickplates

Tuffy doors are meant for high-usage areas, and include a third hinge and kickplates on the interior and exterior of the door and frame. 1/8" or heavier kickplates can be provided on the interior and exterior of doors located in heavy traffic areas to protect the door from damage.

## 8. Exterior & Interior Ramps

To eliminate a step-up into the walk-in, a ramp can be installed. An interior ramp is available for limited, light duty, roll-in traffic. Exterior ramps can be removable and will not interfere with the interior storage area. Interior ramps are available when exterior space is limited. Ramps are also available for heavy duty use. Standard interior ramp sizes are 30", 34", 36", and 48" x 27" deep. Standard exterior ramp sizes are 30", 34", 36", and 48" x 32" deep.

# WALK-IN DOOR & BOX ACCESSORIES (CONTINUED)

## 9. Bumper Rail

To prevent damage to walk-ins in heavy traffic areas, we offer different types of bumper rails. They are available in extruded aluminum with a vinyl insert, hat-shaped, and triangular models in either stainless steel or aluminum.

## 10. Outdoor Membrane Roof (Flat or Sloped)

For walk-ins installed outdoors that need a waterproof seal, a membrane roof cap is available. It is constructed from a 1 mm thick Duro-Last single-ply roof membrane. Necessary installation instructions are provided.

## 11. Locking Bar

For better security, we provide an optional locking bar that connects to an inside safety release, which prevents anyone from being locked inside.

## 12. Strip Curtains

To lessen the amount of cold air that escapes while a cooler or freezer door is open for extended periods of time, strip curtains are available in various sizes. Strip curtains reduce energy consumption and the compressor workload, while helping to extend product shelf life by maintaining a more consistent temperature inside your walk-in. In addition, we also offer Clear Vu swing doors for the interior opening. Clear Vu doors extend compressor life and help maintain a constant box temperature. They are not affected by moisture and will not drag over carried items.

## 13. Lighting

Tafco offers many different lighting solutions to meet your specific lighting needs. We offer incandescent, fluorescent, and LED lighting at the doors. The fluorescent and LED lighting options are available in 4' lengths.

## Other Walk-In Accessories

(Consult Factory for more information)

- Manual Sliding Doors
- Electric Sliding Doors
- Bi-Parting Doors
- Glass Man Doors
- Sliding Glass Doors
- Stationary Windows
- GFI Outlets
- Outdoor Rainhoods & Switch Covers
- Inner Door Seal Kits
- Inswing Doors
- Foot Treadles
- Glass Display Doors with Flat or Gravity Feed Shelving

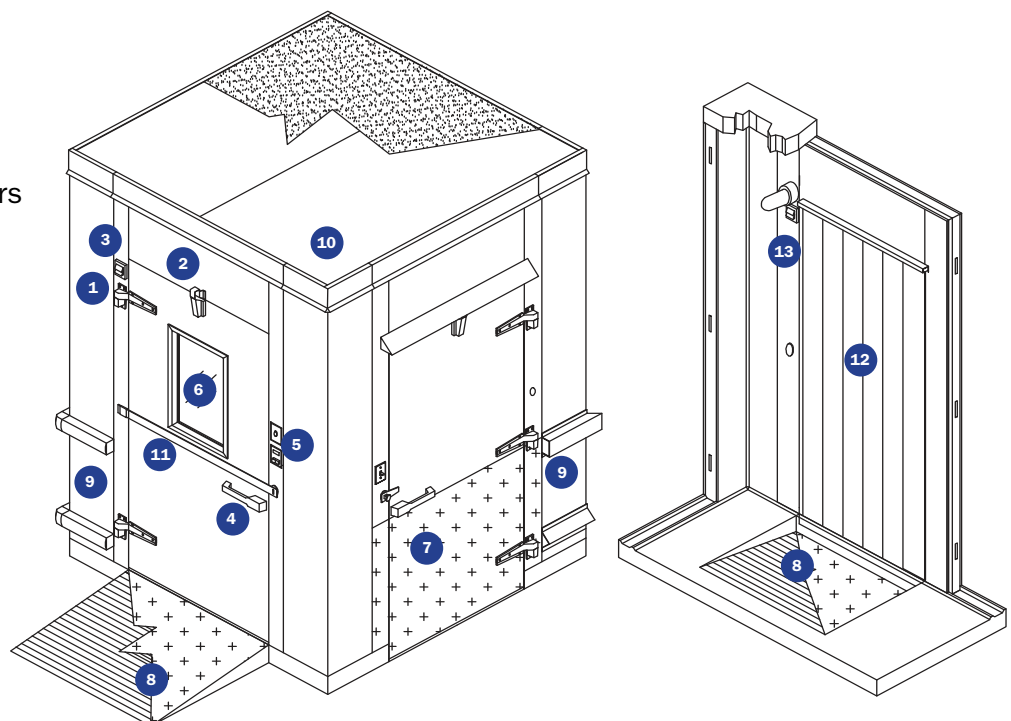

# RETROFIT DOORS & FRAMES

## TAFCO Replacement Insulated Doors & Frames

Cooler doors and frames are subject to more punishment than any other part of the walk-in. They can end up being badly damaged after years of wear. When you are in need of a replacement Tafco cooler door or frame, we are usually able to manufacture a replacement using the serial number on the box. If this information is not available, we have a replacement cooler door and frame detail page that can be filled out and sent to us. If you have a cooler door or frame in need of repair that is not a Tafco cooler, we are able to fit it with a retrofit overlap door.



**REPLACEMENT FRAME DETAIL**

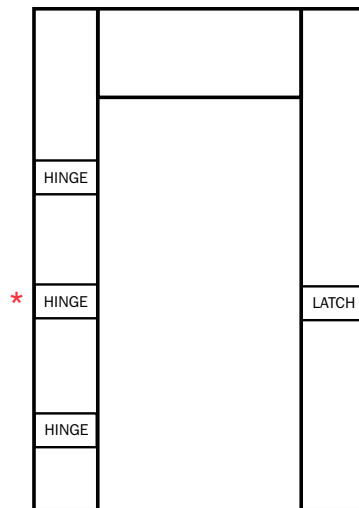

\*3rd Hinge Optional

**REPLACEMENT DOOR DETAIL**



---

## OVERLAP DOOR WITH JAMB

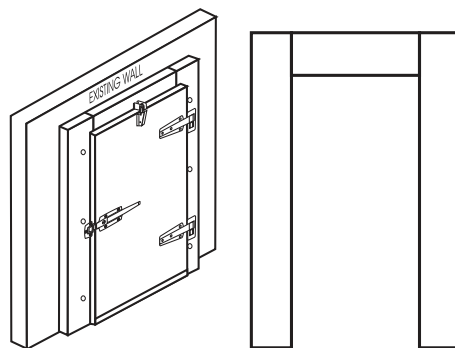

Please visit our website @ [www.walkins.com](http://www.walkins.com) (Products/Replacement Doors page) to obtain full versions of the Doors and Frames detail sheets/order forms for submittal.

# ENGINEERING CAPABILITIES

At Tafco, we are a solutions-based company. We take great pride in developing solutions for our customers, drawing upon our years of engineering experience and expertise, and backed by responsive customer service. We have been a provider of high quality walk-in boxes for over 50 years. Working closely with our customers, the Tafco Engineering Department will design the perfect box for your particular application. We always keep your budget in mind, eliminating any unnecessary costs to manufacture the most cost effective solutions for our valued customers. Our Engineering staff has an average of 12 years experience in this industry and, time and again, have effectively tackled a wide range of challenges in producing the right walk-in for every situation.

## STANDARD BOX WITH ANGLED WALLS

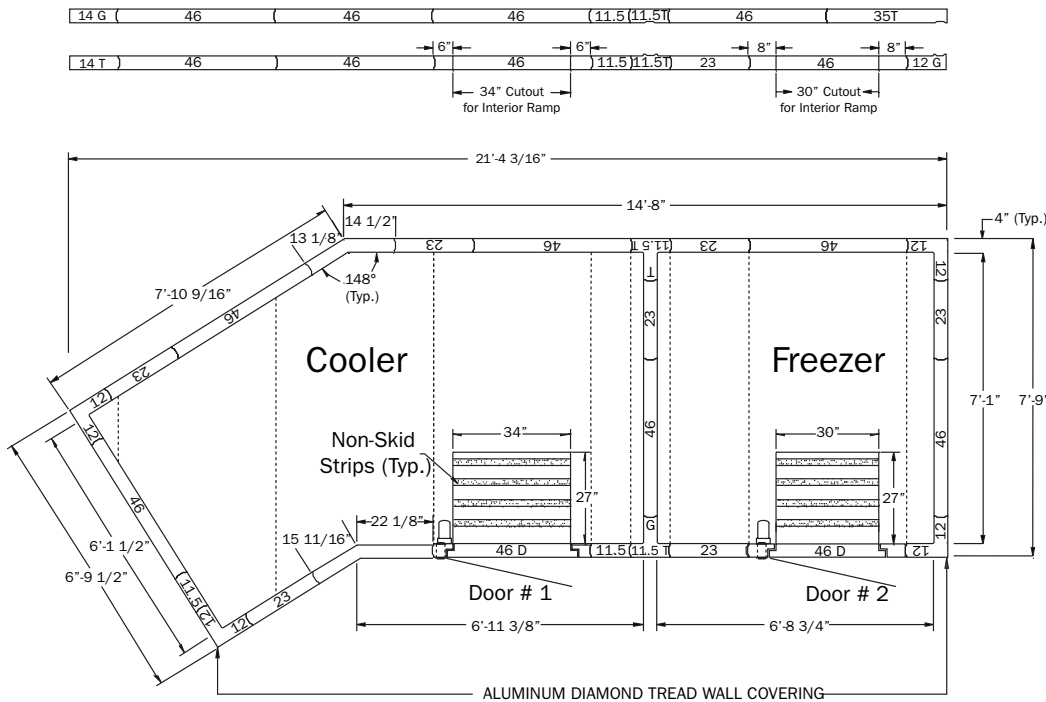

Floor Type 1 with Internal Ramp

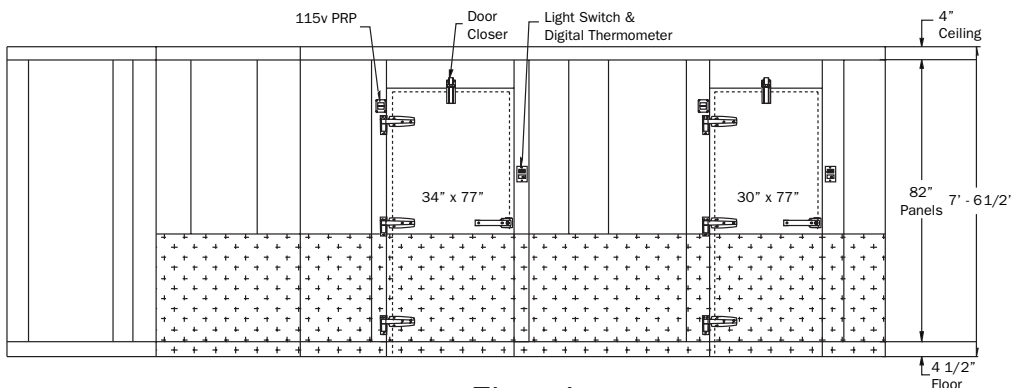
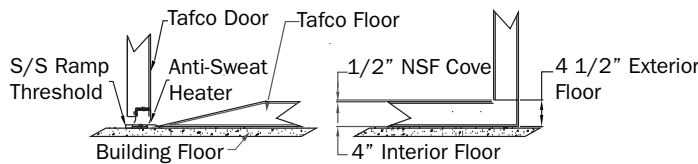

Elevation

For more information, including more information on our capabilities and services, please visit our website at: [www.walkins.com](http://www.walkins.com)

# CUSTOMER SERVICE

In addition to our engineering expertise, we ensure that our customers are completely satisfied with the products they receive through our highly skilled and caring Customer Service Department. Our people work together to always ensure a favorable outcome with every customer. Our Sales, Quotation, Engineering, and Customer Service teams are always available to speak to our customers about any questions or concerns that you may have. We take great pride in being able to respond quickly and knowledgeably to our customers, from start to finish, and in ongoing service to our customers. Responsive customer service allows us to deal quickly with any issue that may arise, large or small.

## Some of Our Nationally Known Installations

- The White House, Washington, DC
- PNC Ball Park, Pittsburgh, PA
- Navy Annex, Washington, DC
- VA Hospital, Philadelphia, PA
- Maricopa Prison, Maricopa, AZ
- Columbia University, New York, NY
- University of California, Irvine, CA
- Genetech, Louisville, KY
- University of New Mexico, Albuquerque, NM
- University of Oklahoma, Oklahoma City, OK
- American Red Cross, Johnstown, PA
- American Red Cross, Atlanta, GA
- Cornell University, New York, NY
- Children's Hospital, Philadelphia, PA
- New York University, New York, NY
- Maumee State Park, Maumee, OH
- Yankee Stadium, New York, NY
- Federal Correction Institution, Manchester, KY
- United States Soldiers Home, Washington, DC
- Merck Pharmaceuticals, Rahway, NJ
- University of Notre Dame, South Bend, IN
- Trumbull Correction Facility, Leavittsburg, OH
- Green County Correctional, Waynesburg, PA
- Allenwood State Prison, Allenwood, PA
- Somerset State Prison, Somerset, PA
- Coal Township State Prison, Shamokin, PA
- The Cleveland Stadium, Cleveland, OH
- Penn State University, State College, PA
- University of Alaska, Anchorage, AK
- University of Tennessee, Knoxville, TX
- Dunkin Donuts, Various – Chain
- Kentucky Fried Chicken, Various – Chain
- Burger King, Various – Chain
- Arby's, Various – Chain
- Carvel, Various – Chain
- Eat & Park, Various – Chain
- Long John Silvers, Various – Chain
- Red Lobster, Various – Chain
- Checker's Drive Thru Restaurant, Chicago, IL
- Four Seasons, Pittsburgh, PA
- Westin Hotel, San Francisco, CA
- Buffalo Hotel, Buffalo, NY
- Omni Hotel, Philadelphia, PA
- Nittany Lion Inn, State College, PA
- Jefferson County Schools, Louisville, KY
- New York, New York, Las Vegas, NV
- Bruster's Ice Cream, Various – Chain
- Days Inn, State College, PA
- Holiday Inn, Waterloo, NY
- North Hills High School, Pittsburgh, PA
- Warren East High School, Venice, FL
- Shelby County High School, Shelbyville, KY
- Texas Road House Restaurants, Various – Chain
- Wayland School, Centerville, VA
- Oahu Care, Honolulu, HI
- Mrs. Baird's Bakery, Various – Chain
- Rax Roast Beef, Various – Chain
- Ground Round, Various – Chain
- Kroger Company, Various – Chain
- I Can't Believe It's Not Yogurt, Various – Chain
- Italian Oven, Various – Chain
- Andrews Air Force Base, Washington, DC
- Fort Bragg, Fayetteville, NC
- Fort Bliss, Fort Bliss, TX
- Fort Ord, Seaside, CA
- Bagel Boss, Brooklyn, NY
- Osan Air Base, Osan, South Korea

# INSTALLATION & DELIVERY

Tafco has manufactured high-quality, energy-efficient walk-ins for over 50 years. We are keenly aware of how important it is to get your installation done right, the first time, every time. Our team of factory employed service technicians, and factory trained sub-contractor partners from across the U. S. and Canada, manage the delivery and installation process of your new equipment every step of the way. When an installation is done efficiently and correctly, the life of your walk-in is increased, energy costs are reduced, and you get years of trouble-free operation.

## Benefits for Dealer/Reps

- Efficient Delivery and Installation
- Nationwide Delivery and Installation by Tafco People
- Single Source from Manufacturing to Completed Installation
- Smooth Start-up = Happy Customers
- Reduction in Warranty Issues
- Affordable Installations
- Faster/Better Service Support for Your Customers

## Benefits for End Users

- Smooth, No-hassle Installation
- Lower Overall Acquisition and Start-up Costs
- Longer Life of Walk-in
- Lower Energy Costs
- Reduction in Warranty Issues
- Affordable Installations
- Local Tafco Approved Service Technicians for Going Forward Care

## Tafco: Installation & Service Experts for Your Walk-In

Tafco's installation and delivery process is a real bonus for our customers. Tafco's trucks deliver your walk-in direct to the job-site, assuring we adhere to your scheduled delivery of the complete walk-in unit. The unit is carefully loaded and unloaded by Tafco authorized personnel avoiding any potential mishandling by a common carrier. This process also eliminates the need for expensive crating, and crating disposal.



Installations range from general box erection to complete turn-key. Our people are specially trained in both refrigeration and panel installation, thus we provide a total cold storage solution to your installation. And with Tafco, you'll work with a single point of contact throughout the installation and delivery process.

**Extended Year Warranty:** When using Tafco's delivery and installation start-up, your regular one year warranty is extended to two years on parts and labor! All other terms and conditions of the standard Tafco warranty apply.

Tafco offers several Installation & Delivery options to best meet your needs, including: delivery only, delivery + installation, or customer arranges delivery and Tafco installs. Installation & Delivery costs are determined by the distance involved and the size of the unit. Estimates can be provided upon request.

**Contact Tafco today at: [800-233-1954](tel:800-233-1954) or [info@walkins.com](mailto:info@walkins.com)**

## **TAFCO 10 YEAR PANEL WARRANTY**

Tafco warrants to the Original Purchaser of the Tafco foamed-in-place panels manufactured and sold by it, to be free from defects in material and workmanship under normal use and service for a period of ten (10) years from the date of original shipment. Painted surfaces shall be warranted 18 months from the date of shipment. All hardware and electrical components (except lights and refrigeration systems, covered separately) are warranted against defects in workmanship under normal use and service for a period of one year from date of shipment. The obligation of the manufacturer under this warranty shall be limited to repairing or replacing (not including labor) at their option FOB factory, panels, hardware, and electrical components which prove defective within the warranty period.

UNDER NO CIRCUMSTANCES WHATSOEVER SHALL TAFCO BE LIABLE TO PURCHASER, OR TO ANY PERSON, FOR ANY SPECIAL OR CONSEQUENTIAL DAMAGES INCLUDING, BUT NOT LIMITED TO, LOSS OF PRODUCT STORED IN A TAFCO COOLER OR FREEZER OR LOST PROFIT OR BUSINESS OPPORTUNITY. UNDER NO CIRCUMSTANCES SHALL TAFCO BE LIABLE FOR ANY AMOUNT IN EXCESS OF TAFCO PRICE FOR GOODS SOLD BY TAFCO.

**THESE WARRANTIES ARE IN-LIEU-OF ALL OTHER WARRANTIES EITHER EXPRESSED OR IMPLIED.**

**For assistance with a warranty, please contact our Warranty Department.**

**1395 Industrial Park Road  
Clearfield, PA 16830**

**Phone: 814-765-9615  
Fax: 814-765-5410  
Toll Free: 800-233-1954  
[www.tafcowalkins.com](http://www.tafcowalkins.com)**